

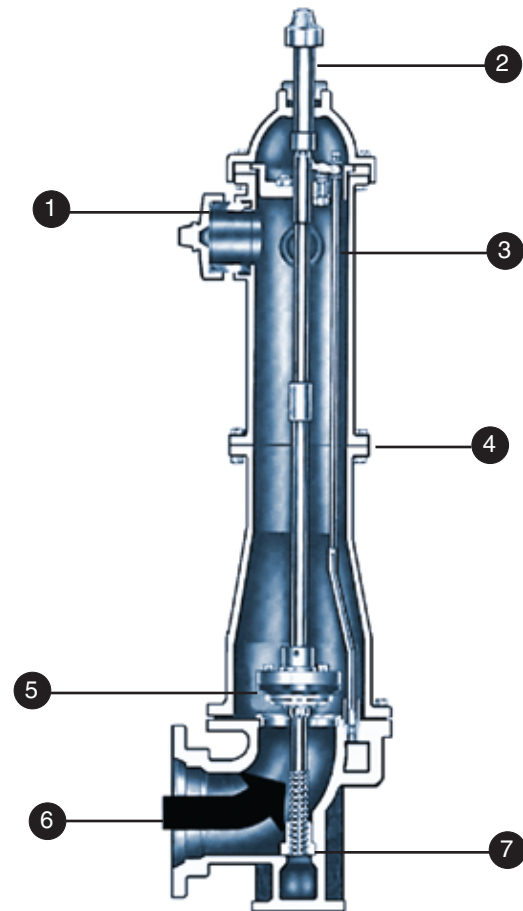

Eddy F-2640 Features



- Time Tested Performance — same design and parts since 1875
- Conforms Fully with AWWA C-502
- Opens Easily and Quickly with Pressure
- Both Drain and Drainless Features are Standard

NOTE: If you would like to learn more about the Clow Eddy F-2640 Hydrant please contact your local Team EJP sales office for more information or to schedule a demonstration.

- 1. Threaded Nozzles:** Easy replacement locking pin to hold nozzle in place; O-Ring Seal
- 2. Rising Stem:** Lets you know position of main valve — Indicator Feature
- 3. Independent Drain:** Allows plugging of drain without disassembly of hydrant
- 4. Break Flange Design:** For traffic safety
- 5. Main Valve Closes Against Pressure:** Eliminates valve seat damage reducing the slam hazards of water hammer
- 6. Main Valve Opens With Pressure:** Water assists in opening the valve making operation easier, faster and positive
- 7. Stem Nut Below Ground Line:** Maintains positive shut off of main valve after traffic damage — Does not depend on water pressure — Never needs lubrication — Bronze to Bronze Connection

NOTE: Epoxy coated shoe provided at no extra cost.

Hydrants D-16

Clow Eddy F-2640

Ordering Information:

- Quantity of hydrants and accessories required
- Size of main valve opening: 4½" or 5¼"
- Size and number of hose nozzles
- Size and number of steamer nozzles
- With or without chains or nozzles
- Hose and pumper nozzle thread specifications
- Type of inlet connection
- Depth of trench or bury
- Direction of opening
- Size and shape of operating nut and cap nuts
- Specify with drain or without drain

BURY	DIR. TO OPEN	PRODUCT NUMBER	
		HYDRANT W/DRAIN	HYDRANT L/DRAIN
5' 0"	OL	42332	42333
5' 6"	OL	42357	42354
6' 0"	OL	42351	42352
6' 6"	OL	42357 02	42390
7' 0"	OL	42357 04	42357 05
7' 6"	OL	42357 07	42357 08
5' 0"	OR	42357 2	42357 3
5' 6"	OR	42358	42358 1
6' 0"	OR	42360	42360 7
6' 6"	OR	42359 05	42359
7' 0"	OR	42362	42361
7' 6"	OR	42362 5	42362 7

Eddy Break Repair Kit



VALVE OPENING	PRODUCT NUMBER	
	HYDRANT W/DRAIN	HYDRANT NO DRAIN
5¼"	42377 1	42377

Specifications:

Eddy F-2640 Hydrant with Drain

- Hydrant shall be center stem type and in accordance with AWWA Standard C-502-85.
- Hydrant shall be compression type with the main valve opening with the water pressure and have a rising stem to positively indicate open or closed position.
- Hydrant shall be furnished with frangible break flange and break coupling at the groundline.
- Bronze stem threads shall be located below the main valve to eliminate necessity of lubrication and in case of damage to hydrant, main valve will remain mechanically closed.
- Hydrant shall have minimum valve opening of either 4½" or 5¼", and shoe inlet of 6".
- Hydrant shall be designed to permit removal of all working parts without special tools or wrenches.
- Hydrant shall have automatic drain, independent of main valve, to provide removal or adjustment without shutting off water and can be cleaned without digging.
- Hydrant shall be the Eddy Hydrant, manufactured by the Clow Valve Company.

Eddy Top Extension



SIZE & LENGTH	PRODUCT NUMBER	
	HYDRANT W/DRAIN	HYDRANT NO DRAIN
5¼" x 6"	42364	NS 13
5¼" x 12"	42366	NS 13
5¼" x 18"	42371	NS 13
5¼" x 24"	42367	NS 13

Hydrants D-17

Clow Eddy F-2640



Eddy F-2640 Parts

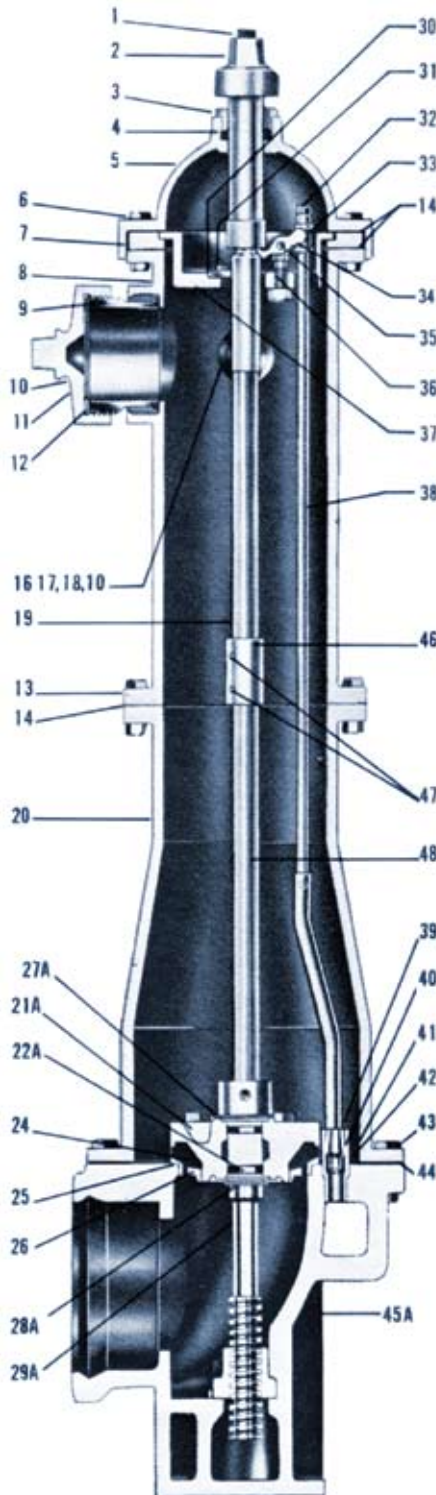

PART NO.	QTY	DESCRIPTION	MATERIAL	PRODUCT NUMBER
1	1	Hold Down Bolt	Stainless	42388
2	1	Operating Nut O.L.	Cast Iron	42388 01
2	1	Operating Nut O.R.	Cast Iron	42388 02
3	1	Packing Nut	Bronze	42388 03
4	1	Packing	Fiber	42388 04
5	1	Cover	Cast Iron	42388 05
6	8	Cover Bolts & Nuts	Steel	42388 06
7	1	Swivel Ring	Cast Iron	42388 07
8	1	Nozzle Section	Cast Iron	42381
9	**	Pumper Nozzle	Bronze	42372
10	**	Nozzle Chain*	Steel	42388 08
11	**	Pumper Nozzle Cap	Cast Iron	42388 09
12	**	Pumper Cap Washer	Rubber	42388 10
13	8	Flange Bolts & Nuts	Steel	42376 3
14	3	Flange Gaskets	Accopac	42388 11
15	**	Hose Nozzle O-Ring*	Rubber	42388 12
15	1	Pumper Nozzle O-Ring*	Rubber	42388 121
16	**	2.5" Hose Nozzle	Bronze	42373
17	**	2.5" Hose Nozzle Cap	Cast Iron	42388 13
18	**	2.5" Hose Cap Washer	Rubber	42373 1
19	1	Upper Stem	Stl. & Bronze	42388 14
20	1	Standpipe	Cast Iron	42388 15
21A	1	Valve Plate	Cast Iron	42388 16
22A	2	O-Ring	Rubber	42388 17
24	1	Valve Rubber	Rubber	42378
25	1	Seat Ring	Bronze	42388 18
26	1	Throttling Ring	Bronze	42388 19
27A	2	Thrust Washer	Teflon	42388 20
28A	1	Snap Ring	Stainless	42388 21
29A	1	Lower Stem	Mang. Bronze	42387
30	1	Stem Wedge	Polycarbonate	42388 22
31	1	Stem Wedge Screw	Bronze	42388 23
32	1	Lock Nut	Bronze	42388 24
33	1	Drain Spool	Bronze	42388 25
34	1	Drain Lever	Bronze	42376
35	1	Lever Pin	Bronze	42388 26
36	1	Clevis & Nut	Bronze	42388 27
37	1	Drain Support	Cast Iron	42388 28
38	1	Drain Rod	Steel	42388 29
39	1	Drain Valve Backer	Bronze	42388 30
40	1	Drain Valve Rubber	Rubber	42388 31
41	1	Drain Cup	Bronze	42388 32
42	1	Retaining Nut	Bronze	42388 33
43	**	Bottom B & N	Steel	42388 34
44	1	Bottom Gasket	Accopac	42388 35
45	1	Bottom	Cast Iron	42363
45A	1	Stem Nut Clip	Stainless	42388 37
45B	1	Bottom Nut O.L.	Bronze	42388 38
45B	1	Bottom Nut O.R.	Bronze	42388 39
46	1	Stem Coupling	Steel Tubing	42376 1
47	2	Stem Coupling Pin	Stainless	42376 2
48	1	Middle Stem	Steel	42388 36

* Not Shown

** Quantity As Required

NOTE: When ordering hydrant parts please specify the direction of opening (open left or open right) and the valve opening size (4¼", 4½" or 5¼").